

## SMART wall-mounted, floor-mounted and portable charging stations with WiFi TOWER/STANDARD+ & TOWER/DUO+ & TOWER QUATTRO+ with OCPP/RFID/ISO PC03X+ & PC04X+ & PC05X+ & PC02Y+ & PC04Y+ & PC05Y+ QUICK INSTALLATION AND SETUP GUIDE

rev. 11, 29. 10. 2025 - - - applicable for:

Micro EVSE 3/3.1/3.2 charging controller code version (wall and floor mounted stations): v3.26

WiFi METRON Charge Control application version (wall and floor mounted stations): v1.36

OCPP/RFID module code version (wall and floor mounted stations): v1.17

ISO 15118 HLC UNIT module code version (wall and floor mounted stations): v1.05

Micro EVSE 4 charging controller code version (portable stations): v4.20

WiFi METRON Charge Control application version (portable stations): v2.26X & v2.26Y

3FD-3/3.1/3.2 DYNAMIC EV CHARGING UNIT code version (3FD-3/3.1/3.2 unit): v3.22

WiFi METRON Dynamic Power Control application version (3FD-3/3.1/3.2 unit): v3.27



## INSTALLATION OF STANDARD(+) OR DUO(+) WALL-MOUNTED CHARGING STATIONS

1. Main internal modules/parts in Standard charging station (for Duo it's the same just everything is double):

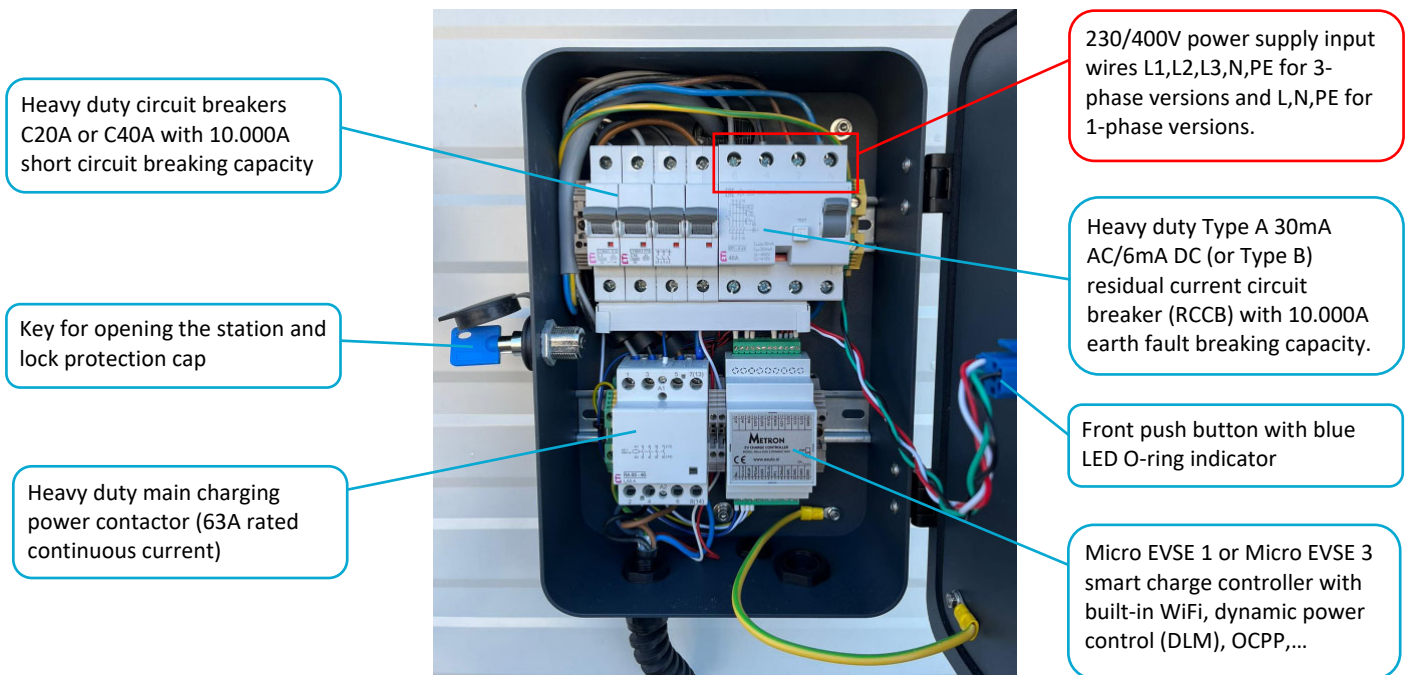

2. Choose suitable mounting location. Make sure the charging station distance to wall, ceiling, other charging station(s) or other obstacles has **at least 30cm of clearance**. Reason: to easily open the front panel/door and to be able to roll-up the charging cable around the station.
3. Choose power and signal cables entrance into the charging station. There are 2 options: **from the back hole or from the bottom cable glands** (enclosed).
4. Use the enclosed **stencil** (part of the packaging) and mark the locations where you will drill holes and then drill the holes into the wall. Screws and plastic wall plugs ( $\Phi$  8mm) for concrete/bricks are enclosed.
5. Fix the wall charging station using 3 (Standard version) or 4 screws (Duo version).
6. Connect the station to 230/400Vac 50Hz (L1, L2, L3, N, PE) power supply. Use cables/wires with suitable cross section **according to local codes and standards**. On Standard stations connect power supply directly to built-in RCCB terminals. On Duo stations connect power supply to separate terminals; some Duo stations can have also totally separated terminals for connection with 2 cables (e.g. powered from different power source).
7. Apply the power supply and check if the right voltage is present on input terminals/RCCB. If yes, switch ON the circuit breakers and RCCB and observe the blinking of blue status LED O-ring on the front side of the station. The number of blinks indicates the maximum charging power to which the station has been set (1 blink=6A, 2=8A, 3=10A, 4=13A, 5=16A, 6=20A, 7=25A, 8=32A).
8. Test the functionality of manual charging current setting by pressing the push button on the front panel (blue status LED OFF) and keep it pressed. After 5 seconds the blue status LED starts to blink (keep it pressed). Count the number of all blinks. After the last blink the blue status LED will switch OFF and you can release the button. 16A charging stations maximum number of blinks is 5; 32A versions have 8 blinks.
9. **Explain to the client** that blinking blue status LED represents charging in progress, status LED ON means that the vehicle is not connected or charging has already been completed.
10. **Explain to the client** that they can set the maximum charging current if they press the button and count the blue status LED blinks. The set value is saved in to the memory and stays saved also in case of power loss.
11. **Explain and demonstrate the client how to connect to built-in WiFi web server and what capabilities the Metron Charge Control application provides** (see page 5).

# INSTALLATION OF TOWER STANDARD(+) OR DUO(+) OR QUATTRO(+) FLOOR-MOUNTED STATIONS

1. First build a concrete foundation with cable conduits for Tower Standard/Duo/Quattro charging station as per below drawings (all dimensions are in mm). Then drill holes, insert expansion anchors and fix the station.

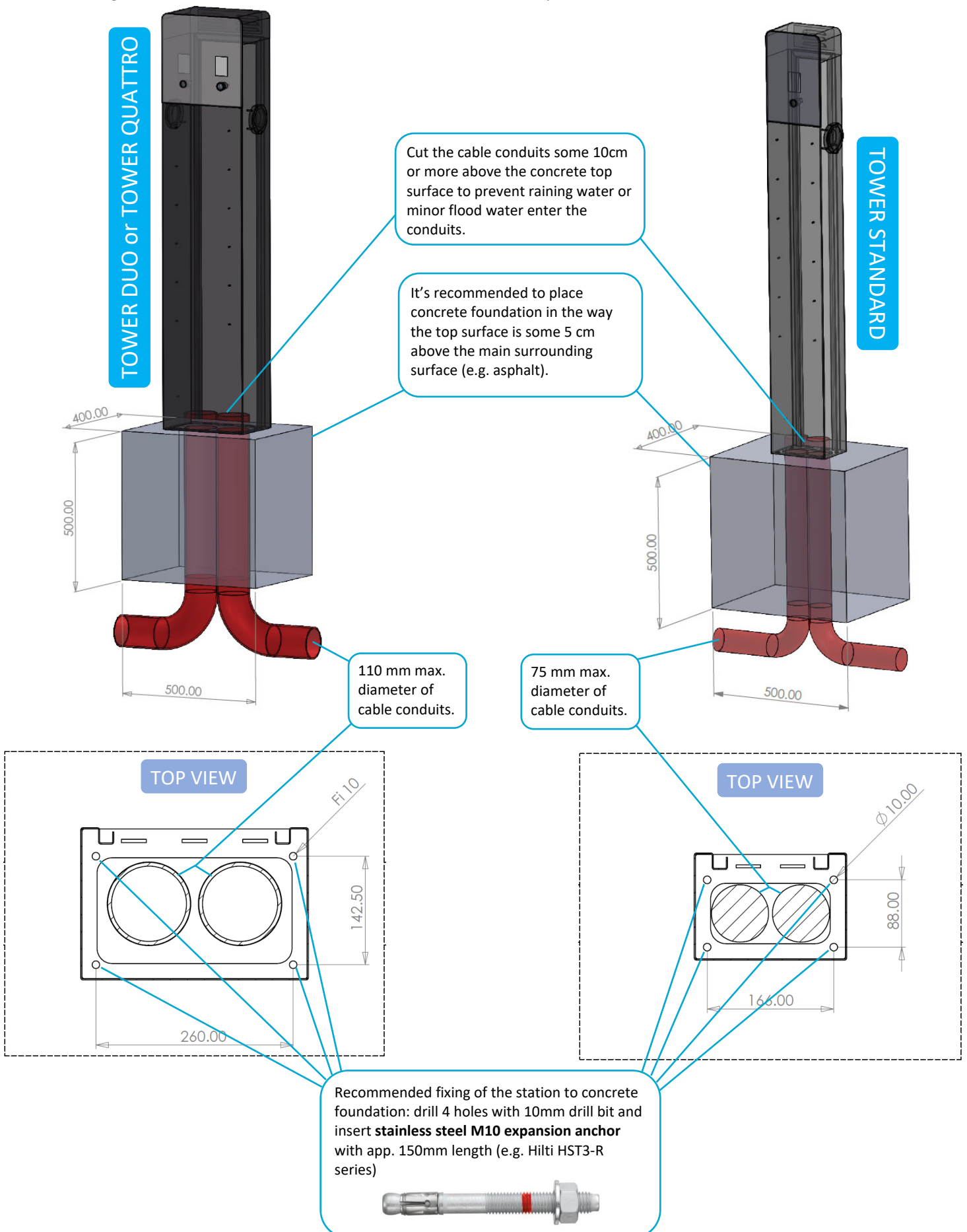

2. Main internal modules/parts in Tower Duo station (for Tower Standard/Quattro it's the same just everything is single/quadruple):

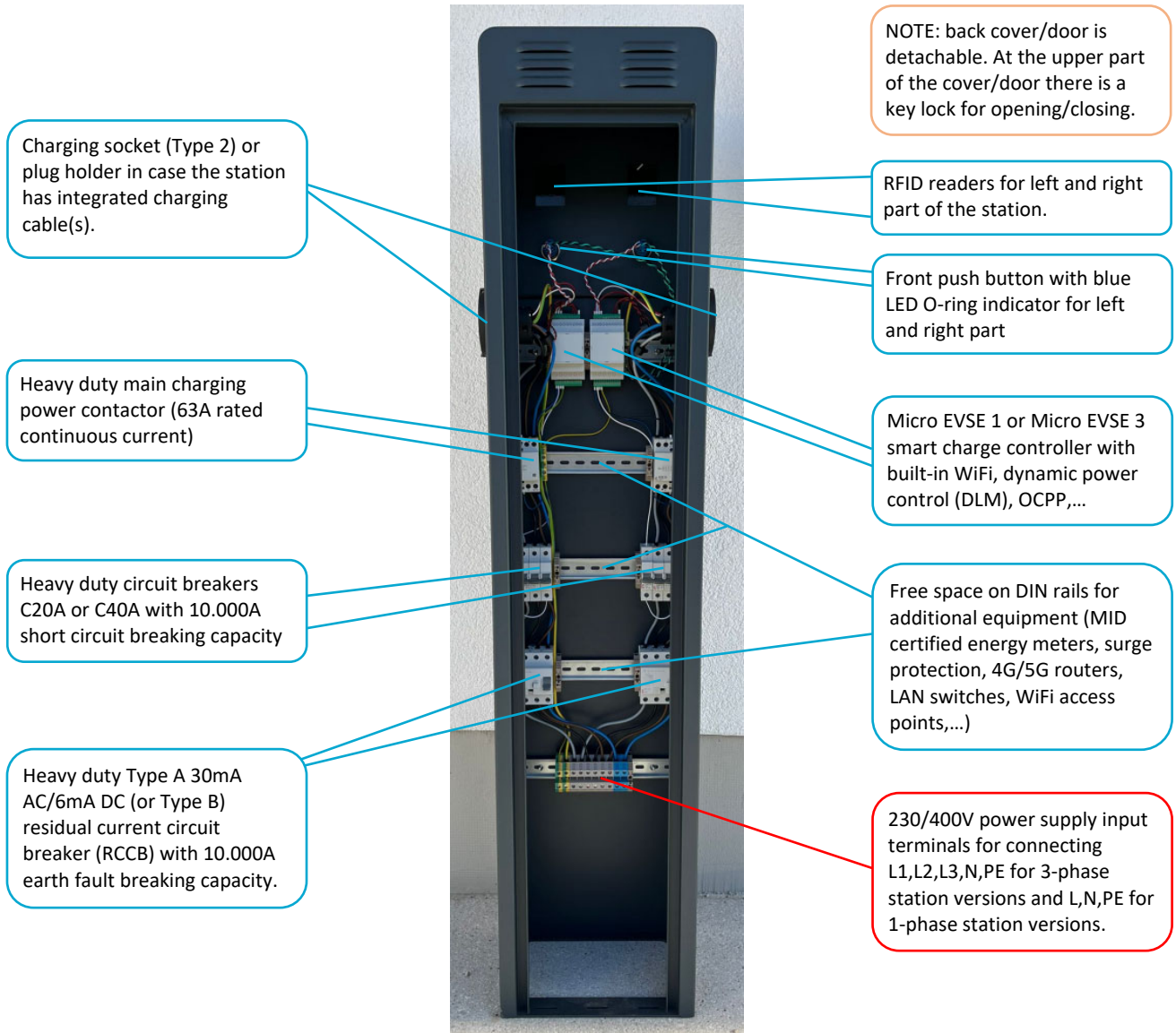

3. Connect the 230/400Vac 50Hz (L1, L2, L3, N, PE) power supply cables/wires to the station bottom terminals. Use cables/wires with suitable cross section according to local codes and standards. On Tower Duo/Quattro stations you can connect each part to it's own power source by separating power supply terminals. This is possible because charging points are totally separated!
4. Apply the power supply and check if the right voltage is present on input terminals. If yes, switch ON the circuit breakers and RCCB and observe the blinking of blue status LED O-ring on the front side of the station. The number of blinks indicates the maximum charging power to which the station has been set (1 blink=6A, 2=8A, 3=10A, 4=13A, 5=16A, 6=20A, 7=25A, 8=32A).
5. Test the functionality of manual charging current setting by pressing the push button on the front panel (blue status LED OFF) and keep it pressed. After 5 seconds the blue status LED starts to blink (keep it pressed). Count the number of all blinks. After the last blink the blue status LED will switch OFF and you can release the button. 16A charging stations maximum number of blinks is 5; 32A versions have 8 blinks.
6. [Explain to the client](#) that blinking blue status LED represents charging in progress, status LED ON means that the vehicle is not connected or charging has already been completed.
7. [Explain to the client](#) that they can set the maximum charging current if they press the button and count the blue status LED blinks. The set value is saved in to the memory and stays saved also in case of power loss.
8. [Explain and demonstrate the client how to connect to built-in WiFi web server and what capabilities the Metron Charge Control application provides \(see page 5\).](#)

**Metron wall-mounted, floor-mounted and portable charging stations with “+” mark have a built-in WiFi access point with web server** what enables users to connect to it wirelessly by any smart phone, tablet or laptop PC. **As there is a web server inside with preloaded METRON Charge Control application you don't need to install any additional application** on your device because the METRON Charge Control runs in your favorite web browser (Google Chrome, Microsoft Edge, Mozilla Firefox,...) on any operating system (Google Android, Apple iOS, Microsoft Windows, Huawei HarmonyOS, Linux,...) you have on your smart phone, tablet or laptop PC.

**The web-based METRON Charge Control application functions:**

- User can set the desired charging current, delay charging start and limit the charging energy.
- User can turn on/off SOLAR SURPLUS charging if solar power plant is installed
- User can switch between 1-phase or 3-phase charging if supported by the station configuration.
- User can set daily Smart scheduled charging; set station on/off and house grid power limit for each of 24 hours.
- User can see all the real time measurements of charging power, charging current and charging energy
- If hardwired or wireless dynamic charging with house main fuse protection and grid power draw limit is enabled/connected the user can also see house load, house energy consumption, solar power and solar energy production.
- User can set activation requirement for charging start to lock the station for unauthorized users
- User can set/activate GUEST MODE (password required) which prevents the users to change settings (applicable for wall mounted stations)
- Allows the user to change WiFi password and WiFi name (ssid) for accessing the Charge Control app.
- Allows the user to connect the charging station to local WiFi network and also set the charging station internet access in the WiFi router (advanced users),
- Allows the user to establish connection to OCPP backend server via WiFi or ETHERNET and read/store RFID cards (applicable for “+” wall mounted stations with OCPP/RFID module installed),
- Allows the user to set AutoCharge authentication for charging start based on vehicle identification number; no need for RFID cards or other authen. methods. (applicable for “+” wall mounted stations with ISO 15118 module installed),
- Allows OVER THE AIR (OTA) UPDATES of the app. firmware via WiFi by manufacturer, certified installer or user.

**In order to connect to the WiFi METRON Charge Control application you need to do the following:**

- Make sure the wall/floor mounted or portable charging station is energized (connected to power).
- Go to WiFi menu in your smart phone, tablet or laptop PC and search for WiFi networks.
- Find “METRON Station 1” (wall/floor mounted stations) or “METRON Portable 1” (portable stations) network and connect to it; enter the WiFi password 12345678 (this is default - it is recommended that you change it in the METRON Charge Control application).
- Scan QR code you find on the station and follow the link (it will open your default web browser and launch the Metron Charge Control automatically; OR open your favorite web browser and go to the following IP address: <http://192.168.4.4>
- The METRON Charge Control application will be loaded immediately.

Up to 5 users (devices) at a time can be wirelessly connected to the charging station and all connected devices will automatically receive all the latest data; for example, if one user changes the charging current with the slider all others will see that on their screens.

If the user forgets the WiFi password you need to do the following:

- Disconnect the wall mounted or portable charging station from power, press the “Push Button” and keep it pressed.
- Connect the station back to power.
- The blue status LED starts blinking 2 times.
- After 30 seconds the status LED will turn-on for 3 seconds and then turn-off.
- Release the “Push Button” and WiFi name (ssid) & password are reset to default values.

The METRON Charge Control application is intuitive and usually doesn't need more instructions to be used; just browse and explore the functions (some important user instructions are explained where the additional user info is required). If you don't understand something please feel free to contact Metron support anytime.

**METRON wall/floor-mounted and portable charging stations can be equipped with hardwired (wall and floor mounted stations only) or wireless DYNAMIC EV CHARGING system which enables charging with main fuse protection and grid power draw limit and in case of installed solar/wind/hydro power plant also solar/wind/hydro SURPLUS charging and POWERFUL charging that adds solar/wind/hydro power to main fuse rating. If you are installing such a charging station please carefully read the guidelines on the next pages.**

**HARDWIRED 1 or 3-phase MAIN FUSE protection DYNAMIC charging**  
**with 1 WALL or FLOOR MOUNTED charging station per main fuse**



1. After installing the charging station as described on the Pages 2 to 4 install the supplied current measuring transformers (CT) on the house/building main power supply input and connect them to **Micro EVSE 3 DYNAMIC WiFi** EV charge controller as shown on the **ME3-1, ME3-1B, ME3-2, ME3-2B or ME3-3** drawings in the attachment.
2. Switch ON charging station power supply.
3. **Set the needed parameters via Metron Charge Control application.** On the first page click/press on “Settings” button and scroll down to “Essential parameters” window where you see the settings. Press “Change parameters” button and enter the password “**param2011**” in order to be able to change settings. Then change settings as needed/required and press “Confirm new parameters” button below to save new settings.
4. DESCRIPTION OF EACH ESSENTIAL PARAMETER the installer can set:

Select 3P+N (most of Europe) or 3P (Belgium and a few other countries) grid system.  
**Default setting: 3P+N (unidirectional)**

Select 1, 2 or 3 phase power plant grid connection.  
**Default setting: 3 phases**

Select 1, 2 or 3 phase house grid connection.  
**Default setting: 3 phases**

Select 1-phase, 3-phase or user selectable 1/3-phase charging if supported by station.  
**Default setting: 3 phases**

Select current measuring range 1, 2 or 3 (CT ratio shall be 2000:1 in all cases):  
**Default setting: Range 1**

Select main fuse rating from 1A to 250A in case of hardwired main fuse protection. In case of wireless dynamic power control is established this setting shall be set to 35A and the actual relevant fuse is then set on wireless dynamic EV charging unit 3FD-3.  
**Default setting: 35 A**

Select house grid power limit from 0kW (Solar SURPLUS charging only) to 173kW or select “No limit” to disable the function. In case of wireless dynamic power control is established this setting is irrelevant because grid power limit is controlled by the 3FD-3.  
**Default setting: No limit**

Set “Hardwired” in case current sensors are connected directly to Micro EVSE 3 controller or “Wireless” if additional Metron Dynamic EV charging unit is used.  
**Default setting: Hardwired**

Station ID (identification) is used for optimized and prioritized wireless main fuse protection dynamic charging. Possible settings are from 1 to 150 what means a maximum of 150 stations can be smartly controlled by the 3FD-3 dynamic EV charging unit. Lower number means higher priority. **You need to select different ID for each by the 3FD-3 controlled wall/floor mounted or portable charging station.**  
**Default setting: 1**

There are 25 channels available in order to prevent interference of wireless signal in case 2 or more Dynamic EV charging units are installed. Micro EVSE 3 DYNAMIC WiFi controller and Dynamic EV charging unit needs to be set to the same channel.  
**Default setting: channel 1**

Set the charging current in case the RF signal is lost (disturbance, 3FD-3 unit failure,...).  
**Default setting: 0 A (safest)**

Front button can be enabled or disabled (recommended for public stations).  
**Default setting: Enabled**

Select if activation/authentication for charging start (RFID, AutoCharge, OCPP backend, via WiFi app., etc) is needed for charging start or not.  
**Default setting: No**

Select local Time zone where the station is installed to get right time (internet needed).  
**Default setting: Central European time**

**General NOTE: Once confirmed the set values stay saved in the internal memory permanently (power loss doesn't delete settings).**

5. **Test the 3/1-phase main fuse protection and grid power draw limit dynamic charging:**  
Connect to WiFi and go to the Metron Charge Control web-based application. Connect the electric vehicle to the charging station and observe the charging current measurements in WiFi Charge Control app. under “Advanced info”. Intentionally put the big load to each of the phases (one by one) to surpass the main fuse rated current or grid power limit and observe if the charging current decreased in the way the total main fuse current is not higher than main fuse rated current or the house total power is not higher than the set grid limit power. To do that you need to connect powerful load to each phase (easiest way is to use regular 2 kW electric heaters – 1,2,3... connected in parallel).
  
6. **Explain to the client** that the charging station will automatically reduce or stop the charging in case of main fuse overload or grid power draw limit is exceeded. **In case of charging interruption because of overload the blue status LED will blink 4 times** (with pause after 4 blinks) until the load on the main fuse or total house power is low enough to resume charging. The main fuse current on the most loaded phase needs to be app. 7A lower than rated fuse current in order the charging station will allow charging to start/resume. The status LED can blink 4 times even if the vehicle is not connected. This will inform the user that the charging cannot start until the other powerful house loads are switched-off.
  
7. **Explain to the client** that in case of installed solar/wind/hydro power plant the charging station **allows vehicle charging with higher overall current than the set nominal main fuse value and with higher power than the set house grid power limit** (this function doesn't work at night of course). Virtual main fuse rated current increase feature is active only in case **Solar/wind/hydro power plant phases = House grid connection phases**.

**WIRELESS** 1 or 3-phase MAIN FUSE protection DYNAMIC charging with **1 or more WALL and FLOOR MOUNTED** charging stations



1. Install the charging station as described on the **Pages 2 to 4**.
2. Switch ON charging station power supply.
3. Set the main fuse rating to 35A (needed only if it has been changed - factory default setting is already 35A) via Metron Charge Control application as described on **Page 6**.
4. **For wall and floor mounted charging stations set house main fuse protection realization to “Wireless”** via Metron Charge Control application as described on **Page 6** (by default it’s set to “Hardwired” what means RF receiver is not activated).
5. If necessary, set the other essential parameters as described on **Page 6**.
6. **Install and set the 3FD-3 DYNAMIC EV CHARGING UNIT as described on pages 10, 11 and 12 or older 3FD-2 DYNAMIC EV CHARGING UNIT as described in QUICK INSTALLATION GUIDE rev.4.** 3FD-3 and 3FD-2 units are compatible, the difference is in max. fuse rating (3FD-2 up to 250A, 3FD-3 up to 1000A), max. number of controlled charging stations (3FD-2 can control up to 30 stations, 3FD-3 up 150 stations) and the 3FD-3 supports grid power limit charging and solar SURPLUS charging.

## WIRELESS 1 or 3-phase MAIN FUSE protection DYNAMIC charging with 1 or more Smart PORTABLE charging stations



1. Connect the smart portable charging station to wall socket (apply the power supply).
2. **Set the needed parameters via Metron Charge Control application.** On the first page click/press on “Settings” button and scroll down to “Essential parameters” window where you see the settings. Press “Change parameters” button and enter the password “**param2011**” in order to be able to change settings. Then change settings as needed/required and press “Confirm” button below to save new settings.
3. DESCRIPTION OF EACH ESSENTIAL PARAMETER the installer can set:

**M** Charge Control

**Essential parameters**

Select grid system:  
3P+N 230/400V 50Hz (most of Europe and off

Select number of solar phases (grid connection):  
3

Select number of house phases (grid connection):  
3

Activation required for charging start:  
No

Metron WIRELESS main fuse protection & solar surplus charging:  
Enabled

Select station ID:  
1

Select wireless RF receiver channel:  
15

Time zone:  
Central European Time

Change parameters

Select 3P+N (most of Europe) or 3P (Belgium and a few other countries) grid system.

Select 1, 2 or 3 phase power plant grid connection.  
**Default setting: 3 phases**

Select 1, 2 or 3 phase house grid connection.  
**Default setting: 3 phases**

Select if activation for charging start by pressing the “Activate charging” button on the first page in Metron Charge Control application is needed or not. If you select “No” the portable charging station will start charging immediately after the vehicle is connected - Plug&charge principle.  
**Default setting: No**

Wireless fuse protection charging can be manually enabled or disabled. If you choose “Disabled” the portable charging station will always charge with the current/power you set by slider or via front button and will not “listen” the 3FD-3 dynamic EV charging unit even if it will be within the wireless range.  
**Default setting: Enabled**

Station ID (identification) is used for optimized and prioritized wireless main fuse protection dynamic charging. Possible settings are from 1 to 150 what means a maximum of 150 stations can be smartly controlled by the 3FD-3 dynamic EV charging unit. Lower number means higher priority. **You need to select different ID for each by the 3FD-3 controlled wall/floor mounted or portable charging station.**  
**Default setting: 1**

There are 25 channels available in order to prevent interference of wireless signal in case 2 or more Dynamic EV charging units are installed nearby (e.g. two neighbour houses). Micro EVSE 4 charging controller and Dynamic EV charging unit need to be set to the same channel in order to work.  
**Default setting: channel 1**

Select local Time zone where the station is installed to get right time (internet needed).  
**Default setting: Central European time**

**General NOTE: Once confirmed the set values stay saved in the internal memory permanently (power loss doesn't delete settings).**

4. **Install and set the 3FD-3 DYNAMIC EV CHARGING UNIT as described on pages 10, 11 and 12 or older 3FD-2 DYNAMIC EV CHARGING UNIT as described in QUICK INSTALLATION GUIDE rev.4.** 3FD-3 and 3FD-2 units are compatible, the difference is in max. fuse rating (3FD-2 up to 250A, 3FD-3 up to 1000A), max. number of controlled charging stations (3FD-2 can control up to 30 stations, 3FD-3 up 150 stations) and the 3FD-3 supports grid power limit charging and solar SURPLUS charging.

**INSTALLING the 3FD-3 DYNAMIC EV CHARGING UNIT for 1 or 3-phase MAIN FUSE protection WIRELESS DYNAMIC charging of up to 150 wall mounted and portable charging stations per main fuse**



1. **Activate wireless FUSE protection and/or grid power limit DYNAMIC charging** on wall/floor mounted station(s) as described on Page 6 (smart portable stations have enabled wireless dynamic charging RF receiver by default). You also need to set house phases, solar phases and station phases but **don't change the main fuse rating on the wall/floor mounted station** (leave default 35 A or set in back to 35A if it has been changed).
2. Install the **3FD-3 DYNAMIC EV CHARGING UNIT** and supplied current measuring transformers (CT) on the house/building main power supply input (in the house main distribution panel) as shown on the **3FD-3-1, 3FD-3-2 and 3FD-3-3** drawings in the attachment.
3. **Set the needed parameters via Metron Dynamic Power Control application. You enter the Dynamic Power Control application** the same way as Charge Control application on stations (see instructions on page 5) except that default WiFi name (ssid) is in this case "METRON Dynamic 1". On the first page click/press on "Settings" button and scroll down to "Essential parameters" window where you see the settings. Press "Change parameters" button and enter the password "**param2011**" in order to be able to change settings. Then change settings as needed/required and press "Confirm new parameters" button below to save new settings.
4. DESCRIPTION OF EACH ESSENTIAL PARAMETER the installer can set:

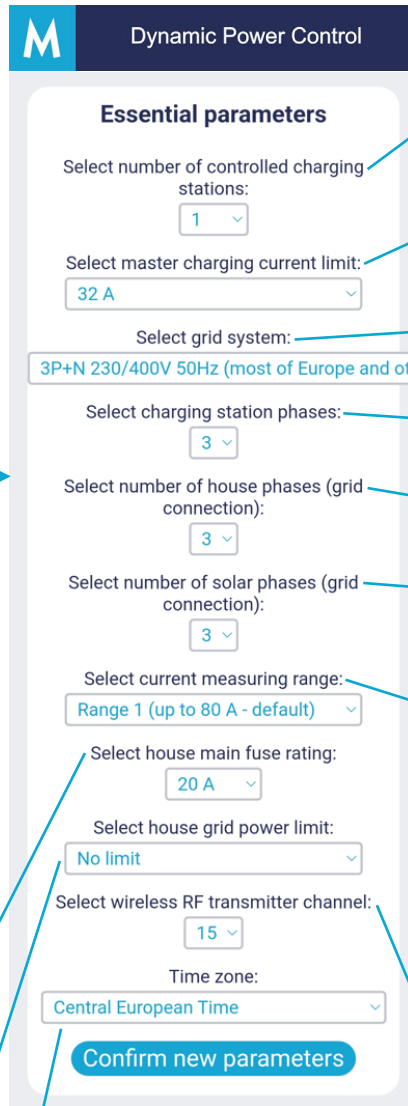
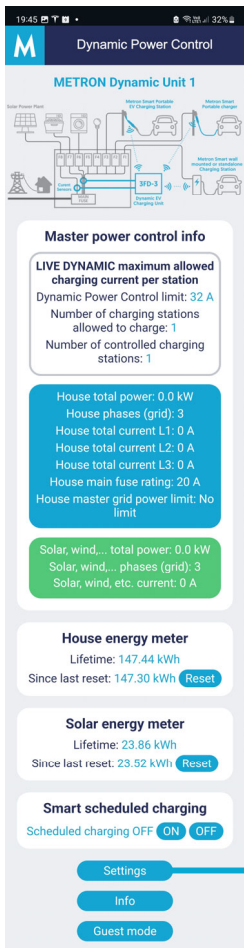

- Select number of stations the 3FD-3 will control. Up to 150 wall mounted and portable charging stations can be controlled by one Dynamic EV Charging Unit. **Default setting: 1 charging station**
- Select MASTER charging current limit in the range of 6A to 32A. This setting represents absolute maximum allowed charging current on each by this 3FD-3 unit controlled station. There is also additional setting 0A which stops charging on all wirelessly controlled charging stations. **Default setting: 32A**
- Select 3P+N (most of Europe) or 3P (Belgium and a few other countries) grid system. **Default setting: 3P+N**
- Select if the 3FD-3 controlled charging stations are 1, 2 or 3 phases. **Default setting: 3 phases**
- Select 1, 2 or 3 phase house grid connection. **Default setting: 3 phases**
- Select 1, 2 or 3 phase power plant grid connection. **Default setting: 3 phases**
- Select current measuring range:
  - **Range 1:** up to **80A** (no further actions, use supplied CTs)
  - **Range 2:** up to **160A** (connect 1 additional 84.5 Ohm resistor between each current measuring input and GND)
  - **Range 3:** up to **250A** (connect 2 additional 84.5 Ohm resistors between each current measuring input and GND)
  - **Range 4:** up to **500A** (connect 6 additional 84.5 Ohm resistors between each current measuring input and GND)
  - **Range 5:** up to **1000A** (connect 12 additional 84.5 Ohm resistors between each current measuring input and GND)**Default setting: Range 1**
- Note: For Range 2,3,4,5 you shall use appropriate current rating measuring transformers (CTs). CT current ratio shall be 2000:1 in all cases.
- Select house main fuse rating - from 1A to 1000A. **Default setting: 35 A**
- Select house grid power limit from 0kW (Solar SURPLUS charging only) to 700kW or select "No limit" to disable the function. **Default setting: No limit**
- Select local Time zone where the 3FD-3 unit is installed to get right time (internet needed). **Default setting: Central European time**
- There are 25 channels available in order to prevent interference of wireless signal in case 2 or more 3FD-3 units are installed nearby (e.g. two neighbor houses). 3FD-3 unit and all wirelessly controlled charging stations shall be set to the same RF channel. **Default setting: channel 1**

**General NOTE: Once confirmed the set values stay saved in the internal memory permanently (power loss doesn't delete settings).**

5. In case there are **more than 1 WALL MOUNTED AND/OR PORTABLE station(s) to be controlled** by the 3FD-3 DYNAMIC EV CHARGING UNIT set the number of charging stations as described on **Page 10**. At the same time you need to set the parameter **station ID** for each wall/floor mounted or portable charging station (see **Page 6 and 9**) in the way **each charging station has its own ID** starting from 1. Example: you have 3 charging stations connected to the same main fuse; set the ID on first one to 1, second one to 2 and on the third one to 3. The station ID is displayed in the WiFi Charge Control app. in “Advanced info” menu. **The DYNAMIC fuse protection charging and grid power limit charging work also in case you have a MIXED configuration - 1 or more wall/floor mounted and 1 or more portable stations powered from the same main fuse!**
  
6. **Test the 3/1-phase wireless main fuse protection and grid power limit dynamic charging:** Connect to WiFi and go to the Metron Charge Control application on one of the wirelessly controlled charging stations. Connect the electric vehicle to the charging station and observe the charging current measurements in WiFi Charge Control app. under “Advanced info”. Intentionally put the big load to each of the phases (one by one) to surpass the main fuse rated or grid power limit and observe if the charging current decreased in the way the total main fuse current or grid power draw is not higher than set values. To do that you need to connect powerful load to each phase (easiest way is to use regular 2 kW electric heaters – 1,2,3... connected in parallel). Simultaneously you can connect to Metron Dynamic power control application on the 3FD-3 unit and observe real time load/currents there also.
  
7. **If there is no signal from the 3FD-3 unit** detected on the charging station side (you can see that information in the WiFi Metron Charge Control application under “Advanced info”) the wall-mounted and floor-mounted charging station will stop charging (or charge at loss of RF signal set amps) and the front blue status LED will blink 4 times as in case of main fuse overload condition but the portable charging station will continue charging with user selected charging current/power – this function is logical for portable stations because when you charge somewhere else where 3FD-3 unit is not present its purpose is to charge.  
 Communication signal detection on wall mounted and floor mounted stations can also be observed if LED2 is connected between terminal 20 and GND on the Micro EVSE 3 DYNAMIC WiFi EV charge controller in the charging station (signal present = LED2 off; no signal = LED2 on). Newer versions of wall/floor mounted stations have status LED that blinks 4 times purple/red color to indicate loss of RF signal condition. Portable stations have blue SIGNAL LED for indicating RF signal presence (signal present = SIGNAL LED on; no signal = SIGNAL LED off).
  
8. **Extending the wireless range of 3FD-3 DYNAMIC EV CHARGING UNIT:** in case the 3FD-3 and controlled stations are far away from each other (50m+ air distance) or there are thick concrete walls in between the signal may be too weak. But there are 2 ways of extending the wireless range:
  - Install bigger external 433 MHz antenna on a station(s). Antenna shall be installed on the outside wall and connected with attached cable to the Micro EVSE 3 DYNAMIC WiFi EV charge controller. This is the most effective way to extend signal range. Note: It is not possible to install additional antenna on portable stations.
  - Install bigger 433 MHz antenna on 3FD-3 DYNAMIC EV CHARGING UNIT. This antenna also helps extend the range but it’s less effective.
  - It’s also possible to add a signal amplifier to the 3FD-3 DYNAMIC EV CHARGING UNIT. Contact us if this would be needed.
  
9. **Explain to the client** that **3FD-3 DYNAMIC EV CHARGING UNIT** distributes the charging power to all wirelessly controlled charging stations equally. However, the client can still adjust the charging power on each station via front button or via current setting slider in WiFi Metron Charge Control application.
  
10. **Explain to the client** that in case of wirelessly controlling only **one (1) charging station** it will automatically reduce charging power or stop the charging in case of main fuse overload or grid power limit overload. **In case of charging interruption because of overload the station’s front blue status LED will blink 4 times** (with pause after 4 blinks) until the load on the main fuse or grid power draw is low enough to resume charging. The main

fuse current on the most loaded phase needs to be app. 7A lower than rated fuse current in order the 3FD-3 will allow charging to start/resume. The blue front status LED can blink 4 times even if the vehicle is not connected. This informs the user in advance that charging cannot start until the other powerful house loads are switched-off.

11. [Explain to the client](#) that in case of wirelessly controlling **two (2) or more charging stations** it will automatically reduce the charging power on all the stations in case of main fuse overload or grid power limit overload. If that is not enough it will stop charging on one or more charging stations starting with the one with **highest station ID number**. **In case of charging interruption because of overload the affected station's front blue status LED will blink 4 times** (with pause after 4 blinks) until the load on the main fuse is low enough to resume charging. If the main fuse is too overloaded by other loads it will stop charging on all the stations. After the load on main fuse is reduced the charging will be resumed starting on the **stations with lower station ID numbers** (lower station's ID numbers have the priority over the higher station's ID numbers). The main fuse current on the most loaded phase needs to be app.  $n \times 7A$  lower ( $n$  = number of stations that will be allowed to resume charging) than rated fuse current in order the 3FD-3 will allow charging to start/resume on the additional  $n$  charging stations. The blue front status LED on one or more stations can blink 4 times even if the vehicle(s) is(are) not connected. This informs the user in advance that charging cannot start until the other powerful house loads are switched-off.
12. [Explain to the client](#) that in case of installed solar/wind/hydro power plant the **3FD-3 DYNAMIC EV CHARGING UNIT allows vehicle charging with higher overall current than the set nominal main fuse value and with higher power than the set house grid power limit** (this function doesn't work at night of course). Virtual main fuse rated current increase feature is active only in case **Solar/wind/hydro power plant phases = House grid connection phases**.
13. [Explain to the client](#) that in case of using the a **PORTABLE CHARGING STATION PC03X+ / PC04X+ / PC05X+ / PC03Y+ / PC04Y+ / PC05Y+** on 2 or more different places (e.g. the client has 2 houses) it is possible to install the **3FD-3 DYNAMIC EV CHARGING UNITS** on 2 or more different locations (e.g. 2 houses) with different main fuses and then just move/use the same PORTABLE CHARGING STATION on those different locations and have everywhere **safe wireless FUSE protection and grid power limit DYNAMIC charging**. The **PORTABLE CHARGING STATION connects automatically to 3FD-3 DYNAMIC EV CHARGING UNIT at every location**.

## OCPP 1.6 management with Micro EVSE 3 DYNAMIC WiFi OCPP charge controller



1. **Micro EVSE 3 DYNAMIC WiFi OCPP charge controller supports OCPP 1.6 communication protocol compliant connection of the charging station to any OCPP backend system.** Most used OCPP functionalities are implementation of payment for charging by RFID card/reading QR code, etc or just monitor the charging energy and changing the charging power. It also allows the operators/users to see station state (car connected, charging, charging complete), charging power, charging current, charging energy, manually activate or stop charging, unlocking the charging connector, resetting the OCPP module and even perform **over-the-air (OTA) updates of the OCPP firmware** if needed. All those OCPP 1.6 functions are supported by Metron Micro EVSE 3 DYNAMIC WiFi OCPP charge controller.
2. All needed settings regarding OCPP 1.6 connection can be set **via Metron Charge Control application**. On the first page click/press on “Settings” button and scroll down to “OCPP 1.6 connection parameters” window.
3. DESCRIPTION OF OCPP PARAMETERS the installer can set:

OCPP module can be enabled or disabled.

Insert WiFi ssid & password in case you want to connect OCPP to the internet via WiFi. The other way to connect it to the internet is via Ethernet port:

If you connect the Ethernet cable to Ethernet port the OCPP module will connect to the internet via Ethernet as a priority connection. If you disconnect Ethernet cable it will automatically try to connect to the internet via WiFi if ssid & password is provided and WiFi signal is present.

Here you get info about OCPP connection – connected to internet via WiFi or Ethernet and information if the OCPP module is connected to OCPP server. Local network IP is also displayed if the OCPP module is connected to local network.

OCPP backend system can control the charging power if needed or requested. If there is no charging power/current limitation provided by OCPP backend a maximum possible station charging power is shown.

You can set the energy meter pulses because different manufacturers have usually different fixed settings. If the MID certified energy meter is ordered with the station we at Metron already set this right.

Here you enter the station unique identifier which can be provided by OCPP backend operator or the OCPP backend operator allows you to set your own identifier.

Here you enter the OCPP backend hostname you get from OCPP backend operator. Connection to OCPP backend can be regular web socket (ws) or secure web socket (wss) which is recommended.

Here you enter port number you get from OCPP backend operator. If you don't get it then just delete everything and leave text box blank. In case of secure web socket connection the port number is always 443.

To increase communication security you can enter OCPP key if supported by the OCPP backend system otherwise leave blank.

After you enter new parameters it is mandatory to confirm them by clicking on “Confirm OCPP parameters” button; that will save new settings and settings take an effect.

**General NOTE: Once confirmed the set values stay saved in the internal memory permanently (power loss doesn't delete settings).**

## LOCAL RFID cards management with Micro EVSE 3 DYNAMIC WiFi OCPP charge controller



1. Micro EVSE 3 DYNAMIC WiFi OCPP charge controller supports reading of ISO/IEC 1443A compatible MIFARE Classic RFID cards.
2. If there is an OCPP connection established and the user scans/swipes the card the card number is sent to OCPP backend to check if the card is authorized or not in order to allow/deny charging. This is the first way the user can use the RFID card/tag.
3. The second way of using the cards is to make local authorization by **ADDING the cards to local list of authorized RFID cards/tags**. This local RFID card list can store up to 100 cards and in case of starting the charging with those locally stored cards you don't need OCPP connection or internet. Beside this the **charging energy per each locally stored card is recorded**. To see how much energy was transferred per each stored card you just scan/swipe the card and the kWh number will be displayed in Charge Control app. in RFID cards management window (Settings page). **Charging energy can also be reset to 0 kWh on each card separately when needed**.
4. DESCRIPTION of local RFID cards management functions:

**Charge Control**

### RFID cards management

Scan card or enter card number  
6A850AB1

Card energy: 9.5 kWh **Reset**

Card status: new card read

**ADD card** **REMOVE card** **CHECK card**

NOTE 5: The station's RFID card reader can read ISO/IEC 14443 A compatible MIFARE Classic (Mini, 1K, 4K) cards. 4 Byte or 7 Byte UID numbers are supported. Maximum 100 cards can be stored in charging station's internal memory!

Number of stored cards: 1

**DELETE all cards**

When you scan/swipe any card you get the card number displayed here in this text box.

After you scan/swipe the card you get card energy info. By pressing the "Reset" button you can reset card's energy to 0 kWh.

After you scan/swipe the card you can click/press:

- ADD card button: this stores the new card to local list of authorized RFID cards
- REMOVE card button: this deletes the card from local list of authorized RFID cards
- CHECK card button: this informs you if the card is stored in the local list of authorized RFID cards or not

Here you get info how many cards are already stored in local RFID list of authorized cards. A maximum of 100 cards can be stored.

Clicking/pressing on "DELETE all cards" button will remove all stored RFID cards from local RFID list of authorized cards. After that the number of stored cards will show 0.

**Additional ISO 15118 HLC UNIT**  
**high level communication module**  
**LOCAL AutoCharge and OCPP AutoCharge management**

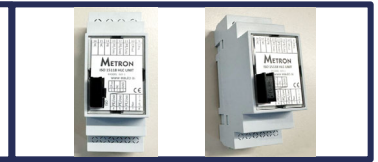

1. In case additional ISO 15118 HLC UNIT is added (installed) to Micro EVSE 3 DYNAMIC WiFi OCPP charge controller an AutoCharge function for automatic vehicle authentication is already supported. When first electric vehicles with V2L capability appear on the market this ISO 15118 HLC UNIT will also support V2G and other functions defined in ISO 15115 standard.
2. If there is an OCPP connection established and the user connects the electric vehicle, the ISO 15118 HLC UNIT will establish a HLC (“High Level Communication”) with the vehicle, read the vehicle identification number (EVCCID) and send it to OCPP backend in to check if the connected vehicle is authorized or not in order to allow/deny charging. This is the first way of using the **AutoCharge** function.
3. The second way of using AutoCharge function is to make local AutoCharge authorization by **ADDING the electric vehicles to local list of authorized vehicles**. This local vehicle list can store up to 100 vehicles and in case of starting the charging with those locally stored vehicles you don’t need OCPP connection or internet. Beside this the **charging energy per each locally stored vehicle is recorded**. To see how much energy was transferred per stored/authorized vehicle you just connect the vehicle to the charging station and the kWh number will be displayed in the Charge Control app. in AutoCharge window (Settings page). **Vehicle charging energy can also be reset to 0 kWh on each vehicle separately when needed**.
4. DESCRIPTION of local AutoCharge management functions:

**Charge Control**

**ISO 15118 module management**

ISO module **ENABLED**  ON  OFF

ISO 15118 PLC connection state:  
Communication with the vehicle established

**AutoCharge management**

AutoCharge **ENABLED**  ON  OFF

AutoCharge EVCCID prefix for OCPP backend authorization:

Vehicle ID (EVCCID): **F07F0C045E78**

Vehicle energy: **167.9 kWh**

Vehicle ID status: **vehicle ID stored**

NOTE 6: Only vehicles supporting ISO 15118 standard can send vehicle ID and other data. Maximum 100 vehicle IDs can be added (stored) to charging station list of authorized vehicles!

Number of stored vehicles (EVCCID): **2**

ISO 15118 module can be enabled or disabled.

AutoCharge function can be enabled or disabled.

You can select EVCCID prefix that is sent to OCPP backend in front of vehicle identification number (e.g. to indicate to the OCPP backend that AutoCharge function is sending the vehicle identification number to authorize)

After you connect the electric vehicle you get the vehicle identification number (EVCCID) displayed here.

After you connect the electric vehicle you get vehicle energy info. By pressing the “Reset” button you can reset vehicle’s energy to 0 kWh.

The information if the connected vehicle is stored in the local list of authorized vehicles or not.

After you connect the vehicle you can click/press:

- ADD vehicle button: this stores the new vehicle to local list of authorized vehicles
- REMOVE vehicle button: this deletes the stored vehicle from local list of authorized vehicles

Here you get info how many vehicles are already stored in local list of authorized vehicles. A maximum of 100 vehicles can be stored.

Clicking/pressing on “DELETE all vehicles” button will remove all stored vehicles from local list of authorized vehicles. After that the number of stored vehicles will show 0.

## MODBUS TCP/IP communication for all SMART wall-mounted, floor-mounted and portable charging stations



1. **All Micro EVSE 3 and Micro EVSE 4 based smart charging stations come with Modbus TCP/IP support; they act as Modbus Slave (server) devices.** Connection to local network is via WiFi only.
2. If there is a Modbus TCP/IP MASTER (client) device (e.g. smart home energy management device) available it can access the station and obtain important charging data (station state, charging current, charging power, charging energy,...) and also set the charging current/power.
3. Modbus MASTER (client) device needs to constantly access the station and send HeartBeat to keep the Modbus connection active otherwise the station will ignore the last Modbus commands and continue charging with user manually set charging current or Metron Dynamic Power Control system limited charging current.
4. To properly set the Modbus MASTER device the registers need to be set. The required data is listed in Metron MODBUS TCP/IP REGISTER TABLE (see attachments).
5. DESCRIPTION of Modbus TCP/IP management functions:

**Charge Control**

### Modbus TCP/IP management

Modbus ENABLED **ON** OFF

Connection active: YES

Local network IP: 192.168.1.11

Modbus limited charging current: 16.0 A

NOTE 4: The Modbus TCP/IP register table is available on the Metron website. For additional assistance, please contact Metron support.

Modbus TCP/IP can be enabled or disabled.

Here you get info about Modbus connection – if the Modbus MASTER device (e.g. smart home energy management computer) is calling the station or not.

Local network IP is also displayed if the station is connected to local network. This information is entered in Modbus MASTER device in order the Modbus MASTER device knows at which local IP address is the station.

If the Modbus MASTER device is guiding the station charging current/power here is displayed the real time Modbus MASTER device defined charging current limit. If the Modbus MASTER device is not sending charging current request, the maximum charging current is displayed (32A).

# ATTACHMENTS

| Mark     | Type    | Description  | Revision |
|----------|---------|--|----------|
| Modbus   | Table   | Metron MODBUS TCP/IP REGISTER TABLE  | 1        |
| ME3-1    | Drawing | 3-phase 3P+N MAIN FUSE protection DYNAMIC charging with 1 wall or floor mounted charging station per main fuse – HARDWIRED option - UNIDIRECTIONAL   | 8        |
| ME3-1B   | Drawing | 3-phase 3P+N MAIN FUSE protection DYNAMIC charging with 1 wall or floor mounted charging station per main fuse – HARDWIRED option - BIDIRECTIONAL  | 0        |
| ME3-2    | Drawing | 1-phase MAIN FUSE protection DYNAMIC charging with 1 wall or floor mounted charging station per main fuse – HARDWIRED option - UNIDIRECTIONAL  | 8        |
| ME3-2B   | Drawing | 1-phase MAIN FUSE protection DYNAMIC charging with 1 wall or floor mounted charging station per main fuse – HARDWIRED option - BIDIRECTIONAL   | 0        |
| ME3-3    | Drawing | 1-phase MAIN FUSE protection DYNAMIC charging with 1 wall or floor mounted charging station per main fuse – HARDWIRED option for 3P 3x230V grid system (Belgium and a few others)                              | 2        |
| 3FD-3-1  | Drawing | 3-phase 3P+N MAIN FUSE protection DYNAMIC charging with 1 or more wall-mounted, floor-mounted or portable charging stations per main fuse – WIRELESS option - UNIDIRECTIONAL                                   | 6        |
| 3FD-3-1B | Drawing | 3-phase 3P+N MAIN FUSE protection DYNAMIC charging with 1 or more wall-mounted, floor-mounted or portable charging stations per main fuse – WIRELESS option - BIDIRECTIONAL                                    | 0        |
| 3FD-3-2  | Drawing | 1-phase MAIN FUSE protection DYNAMIC charging with 1 or more wall-mounted, floor-mounted or portable charging stations per main fuse – WIRELESS option - UNIDIRECTIONAL  | 6        |
| 3FD-3-2B | Drawing | 1-phase MAIN FUSE protection DYNAMIC charging with 1 or more wall-mounted, floor-mounted or portable charging stations per main fuse – WIRELESS option - BIDIRECTIONAL   | 0        |
| 3FD-3-3  | Drawing | 3-phase 3P MAIN FUSE protection DYNAMIC charging with 1 or more wall-mounted, floor-mounted or portable charging stations per main fuse – WIRELESS option for 3P 3x230V grid system (Belgium and a few others) | 3        |

# Metron MODBUS TCP/IP REGISTER TABLE

rev. 1, 7/2025, [www.metron.si](http://www.metron.si), [info@metron.si](mailto:info@metron.si)

Applicable for all Metron smart charging stations and smart portable chargers with Modbus TCP/IP support



| Modbus address | R/W | Modbus function   | Type   | Description   | Range     | Values/comments  |
|----------------|-----|---|--------|---|-----------|--|
| 1              | R   | 0x04 - Read Input Register                                    | uint16 | <b>Charging state</b><br>Value 1 = A1 = EV not connected, station doesn't allow charging<br>Value 2 = A2 = EV not connected, station allows charging start<br>Value 3 = B1 = EV connected without charging request, station doesn't allow charging start<br>Value 4 = B2 = EV connected without charging request, station allows charging start<br>Value 5 = C1 = EV connected with charging request, station doesn't allow charging<br>Value 6 = C2 = EV connected with charging request, station allows charging<br>Value 7 = D1 = EV connected with room ventilation request, station doesn't allow charging<br>Value 8 = D2 = EV connected with room ventilation request, station allows charging<br>Value 9 = E = station or vehicle error | 0...65536 | Station provides only numbers 1,2,3,4,5,6,7,8,9  |
| 10             | R   | 0x04 - Read Input Register                                    | uint16 | Charging current L1   | 0...65536 | 1 = 0.1A (e.g. 160 = 16.0 A)   |
| 11             | R   | 0x04 - Read Input Register                                    | uint16 | Charging current L2   | 0...65536 | 1 = 0.1A (e.g. 160 = 16.0 A)   |
| 12             | R   | 0x04 - Read Input Register                                    | uint16 | Charging current L3   | 0...65536 | 1 = 0.1A (e.g. 160 = 16.0 A)   |
| 20             | R   | 0x04 - Read Input Register                                    | uint16 | Phase voltage L1  | 0...65536 | 1 = 1 V (e.g. 230 = 230 V)   |
| 21             | R   | 0x04 - Read Input Register                                    | uint16 | Phase voltage L2  | 0...65536 | 1 = 1 V (e.g. 230 = 230 V)   |
| 22             | R   | 0x04 - Read Input Register                                    | uint16 | Phase voltage L3  | 0...65536 | 1 = 1 V (e.g. 230 = 230 V)   |
| 30             | R   | 0x04 - Read Input Register                                    | uint16 | Total charging power (L1+L2+L3)   | 0...65536 | 1 = 1 W (e.g. 11000 = 11 kW)   |
| 31             | R   | 0x04 - Read Input Register                                    | uint16 | Charging power L1   | 0...65536 | 1 = 1 W (e.g. 2300 = 2300 W)   |
| 32             | R   | 0x04 - Read Input Register                                    | uint16 | Charging power L2   | 0...65536 | 1 = 1 W (e.g. 2300 = 2300 W)   |
| 33             | R   | 0x04 - Read Input Register                                    | uint16 | Charging power L3   | 0...65536 | 1 = 1 W (e.g. 2300 = 2300 W)   |
| 40             | R   | 0x04 - Read Input Register                                    | uint16 | This charge energy MSB  | 0...65536 | 1 = 1 Wh   |
| 41             | R   | 0x04 - Read Input Register                                    | uint16 | This charge energy LSB  | 0...65536 | (e.g. 38456 = 38456 Wh)  |
| 42             | R   | 0x04 - Read Input Register                                    | uint16 | Lifetime charging energy MSB  | 0...65536 | 1 = 1 Wh   |
| 43             | R   | 0x04 - Read Input Register                                    | uint16 | Lifetime charging energy LSB  | 0...65536 | (e.g. 20344562 = 20344562 Wh)  |
| 50             | R   | 0x04 - Read Input Register                                    | uint16 | Station max. charging current   | 0...65536 | 1 = 1A (e.g. 16 = 16 A)  |
| 51             | R   | 0x04 - Read Input Register                                    | uint16 | Station min. charging current   | 0...65536 | 6 = 6A (fixed number)  |
| 100            | R/W | 0x03 - Read Holding Register<br>0x06 - Write Holding Register | uint16 | <b>Max. allowed charging current command</b><br>Requested charging current values below 6 A (values below 60) stop charging the EV.   | 0...65536 | 1 = 0.1A (e.g. 160 = 16.0 A)   |
| 101            | R/W | 0x03 - Read Holding Register<br>0x06 - Write Holding Register | uint16 | <b>Activate charging command</b><br>If charging station is locked and requires activation to start charging, Master needs to send value 1 only once after the vehicle has been plugged-in and charging will start.  | 0...65536 | 1 = activate charging  |
| 200            | R/W | 0x03 - Read Holding Register<br>0x06 - Write Holding Register | uint16 | <b>Modbus TCP/IP HeartBeat</b><br>Master shall send by 1 increased number or always the same number (any number excluding 50000) once per certain amount of time (e.g. once per 1 or 2 seconds) to keep Modbus connection "alive".  | 0...65536 | In case of no Master activity (e.g. WiFi network failure) for the set WatchDog timeout period (see register 201 description) the station will ignore last Modbus commands and continue charging with user manually set charging current or Metron Dynamic Power Control system limited charging current. |
| 201            | R/W | 0x03 - Read Holding Register<br>0x06 - Write Holding Register | uint16 | Modbus TCP/IP WatchDog timeout  | 0...65536 | 1 = 1 ms (default = 10000 = 10s)   |

Note 1: Values for voltage, current, power and energy are not measured by MID-certified meter and shall not be used for billing purposes. Accuracy of measured values is within +/- 5%.

# INSTALLATION OF METRON Micro EVSE 3/3.1/3.2 DYNAMIC WiFi based WALL or FLOOR MOUNTED CHARGING STATION for **3-phase** DYNAMIC MAIN FUSE PROTECTION CHARGING of **ONE (1)** electric vehicle on **3P+N** grid HARDWIRED OPTION - UNIDIRECTIONAL

3f GRID 3P+N 230/400V/50Hz  
L1 L2 L3 N

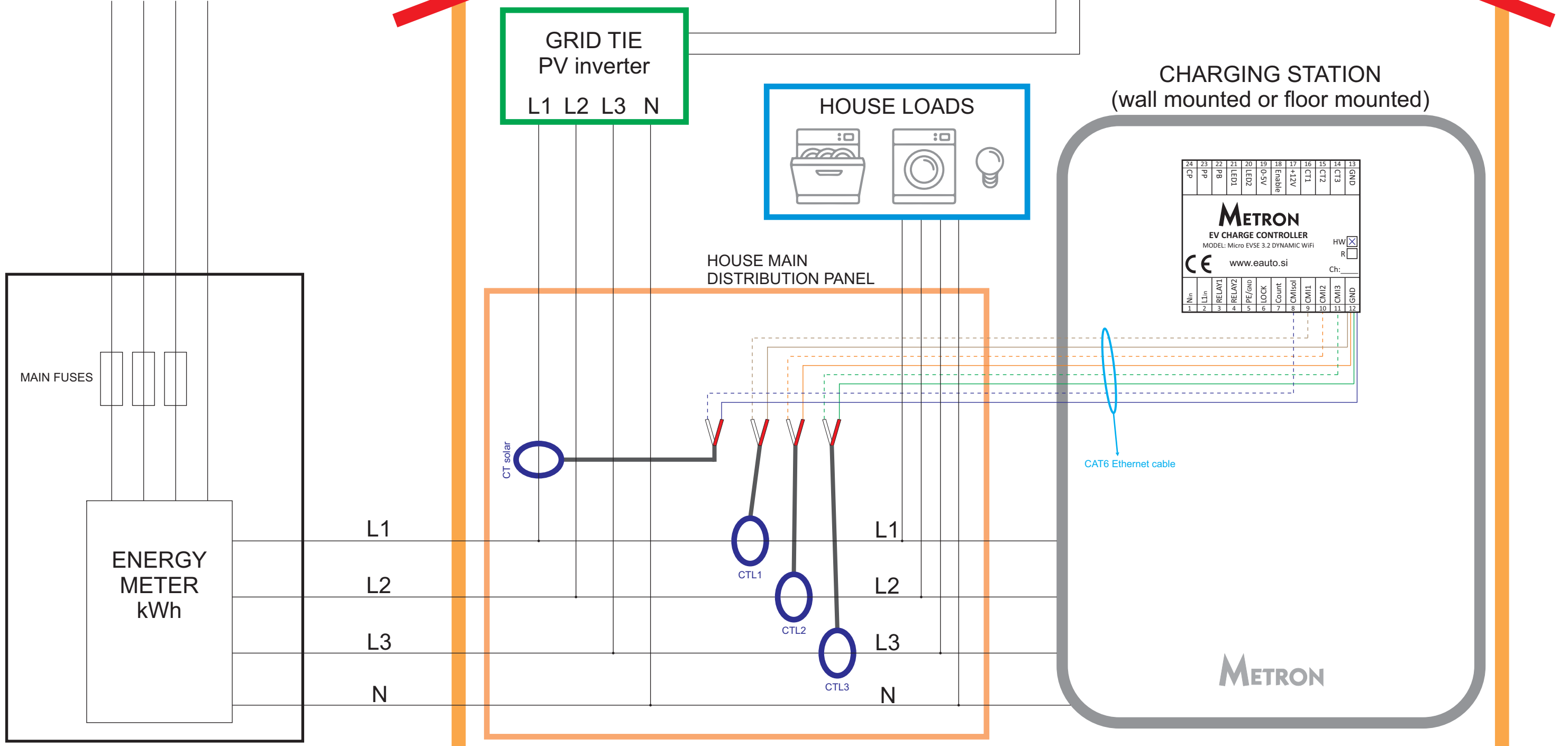

|   |      |        |        |        |        |       |        |      |      |      |     |
|---|------|--------|--------|--------|--------|-------|--------|------|------|------|-----|
| 24  | 23   | 22     | 21     | 20     | 19     | 18    | 17     | 16   | 15   | 14   | 13  |
| CP  | CP   | LED1   | LED2   | 0-5V   | Enable | +12V  | CT1    | CT2  | CT3  | GND  |     |
| <b>METRON</b><br>EV CHARGE CONTROLLER<br>MODEL: Micro EVSE 3.2 DYNAMIC WIFI<br>CE www.eauto.si Ch: <input type="checkbox"/> HW <input checked="" type="checkbox"/> R <input type="checkbox"/> |      |        |        |        |        |       |        |      |      |      |     |
| 1   | 2    | 3      | 4      | 5      | 6      | 7     | 8      | 9    | 10   | 11   | 12  |
| Nin   | L1in | RELAY1 | RELAY2 | PE/gnd | LOCK   | Count | CMisol | CM11 | CM12 | CM13 | GND |

# INSTALLATION OF METRON Micro EVSE 3.2 DYNAMIC WiFi based WALL or FLOOR MOUNTED CHARGING STATION for **3-phase** DYNAMIC MAIN FUSE PROTECTION CHARGING of **ONE (1)** electric vehicle on **3P+N** grid HARDWIRED OPTION - BIDIRECTIONAL

3f GRID 3P+N 230/400V/50Hz

L1 L2 L3 N

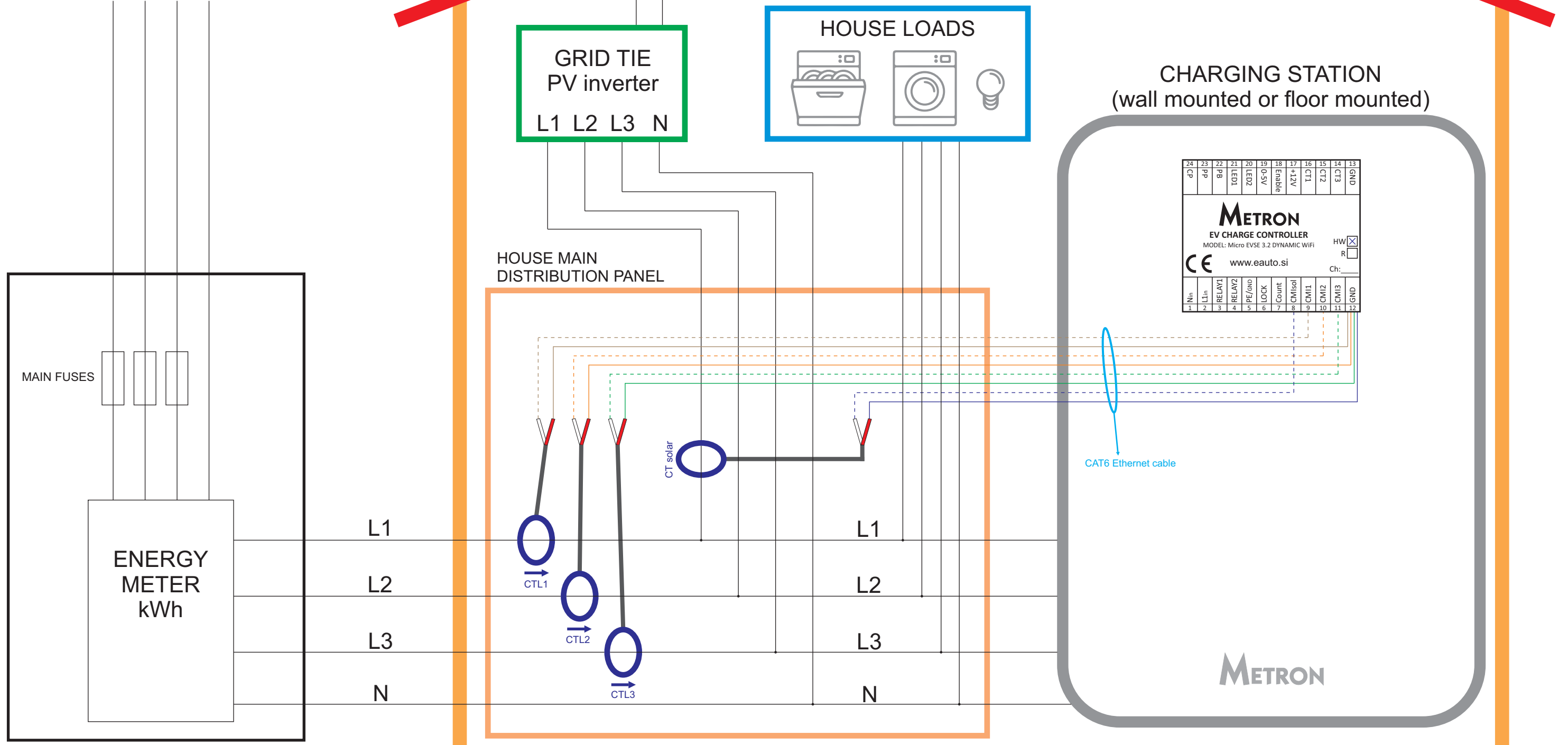

**INSTALLATION OF METRON Micro EVSE 3/3.1/3.2 DYNAMIC WiFi based WALL or FLOOR MOUNTED CHARGING STATION for 1-phase DYNAMIC MAIN FUSE PROTECTION CHARGING of ONE (1) electric vehicle on 1P+N grid HARDWIRED OPTION - UNIDIRECTIONAL**

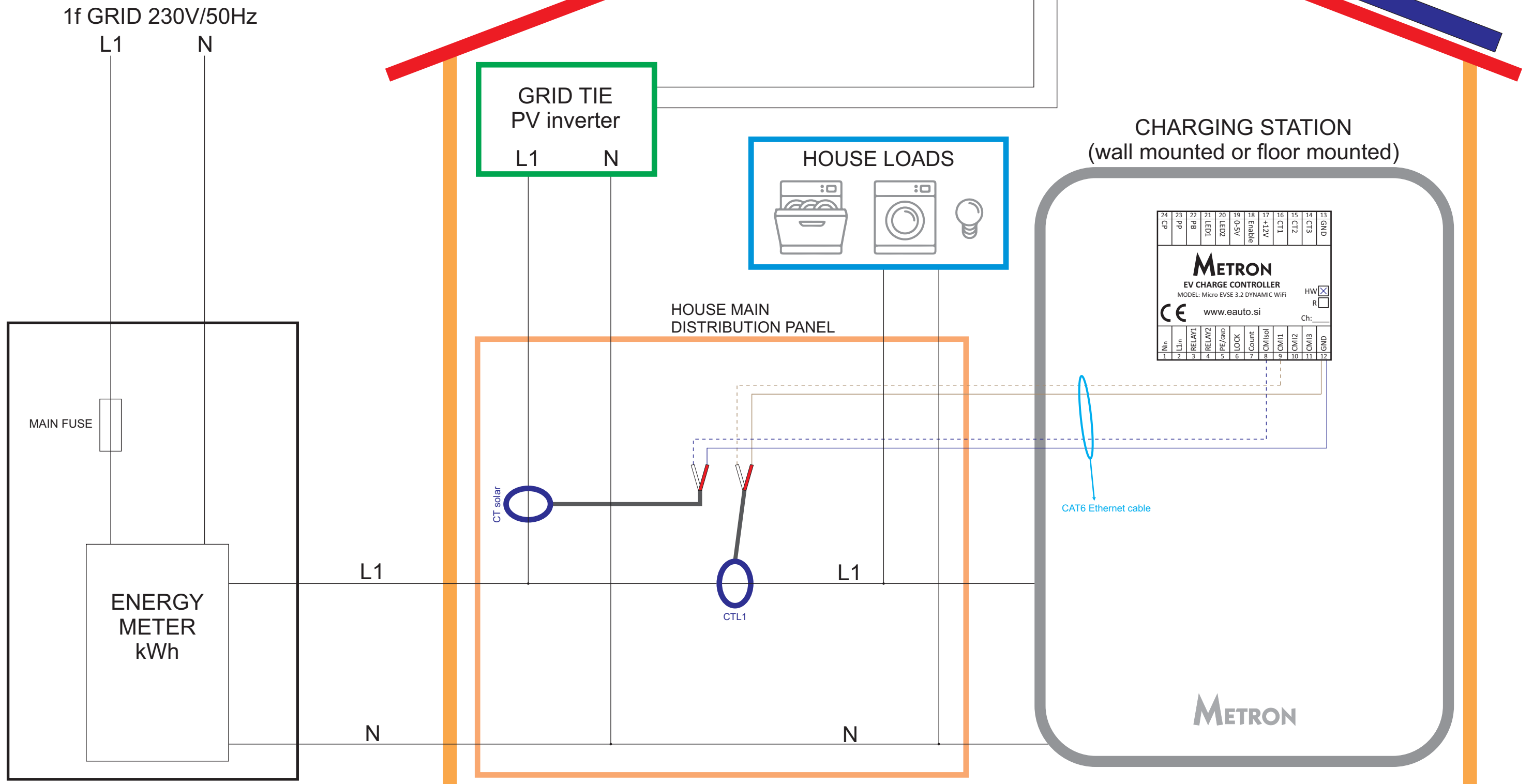

|   |      |        |        |        |        |       |        |      |      |      |     |
|---|------|--------|--------|--------|--------|-------|--------|------|------|------|-----|
| 24  | 23   | 22     | 21     | 20     | 19     | 18    | 17     | 16   | 15   | 14   | 13  |
| CP  | PE   | LED1   | LED2   | 0-5V   | Enable | +12V  | CT1    | CT2  | CT3  | GND  |     |
| <b>METRON</b><br>EV CHARGE CONTROLLER<br>MODEL: Micro EVSE 3.2 DYNAMIC WIFI<br>www.eauto.si<br>CE |      |        |        |        |        |       |        |      |      |      |     |
| 1   | 2    | 3      | 4      | 5      | 6      | 7     | 8      | 9    | 10   | 11   | 12  |
| Nin   | L1in | RELAY1 | RELAY2 | PE/gnd | LOCK   | Count | CM1sol | CM11 | CM12 | CM13 | GND |

**INSTALLATION OF METRON Micro EVSE 3.2 DYNAMIC WiFi based WALL or FLOOR MOUNTED CHARGING STATION for 1-phase DYNAMIC MAIN FUSE PROTECTION CHARGING of ONE (1) electric vehicle on 1P+N grid HARDWIRED OPTION - BIDIRECTIONAL**

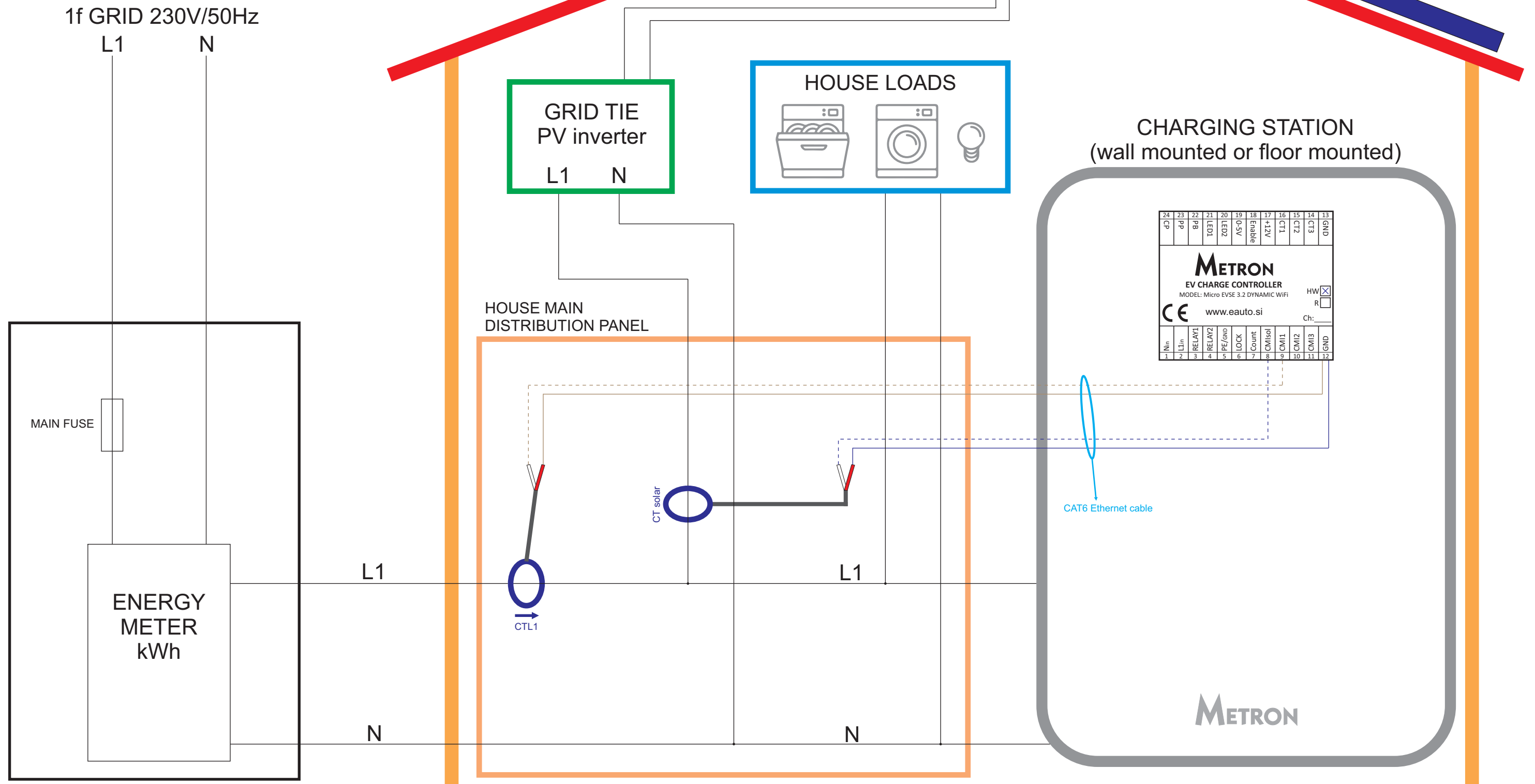

# INSTALLATION OF METRON Micro EVSE 3/3.1/3.2 DYNAMIC WiFi based WALL or FLOOR MOUNTED CHARGING STATION for **1-phase** DYNAMIC MAIN FUSE PROTECTION CHARGING of **ONE (1)** electric vehicle on **3P 230V grid (Belgium)** HARDWIRED OPTION

3f GRID 3x230V/50Hz (Belgium)

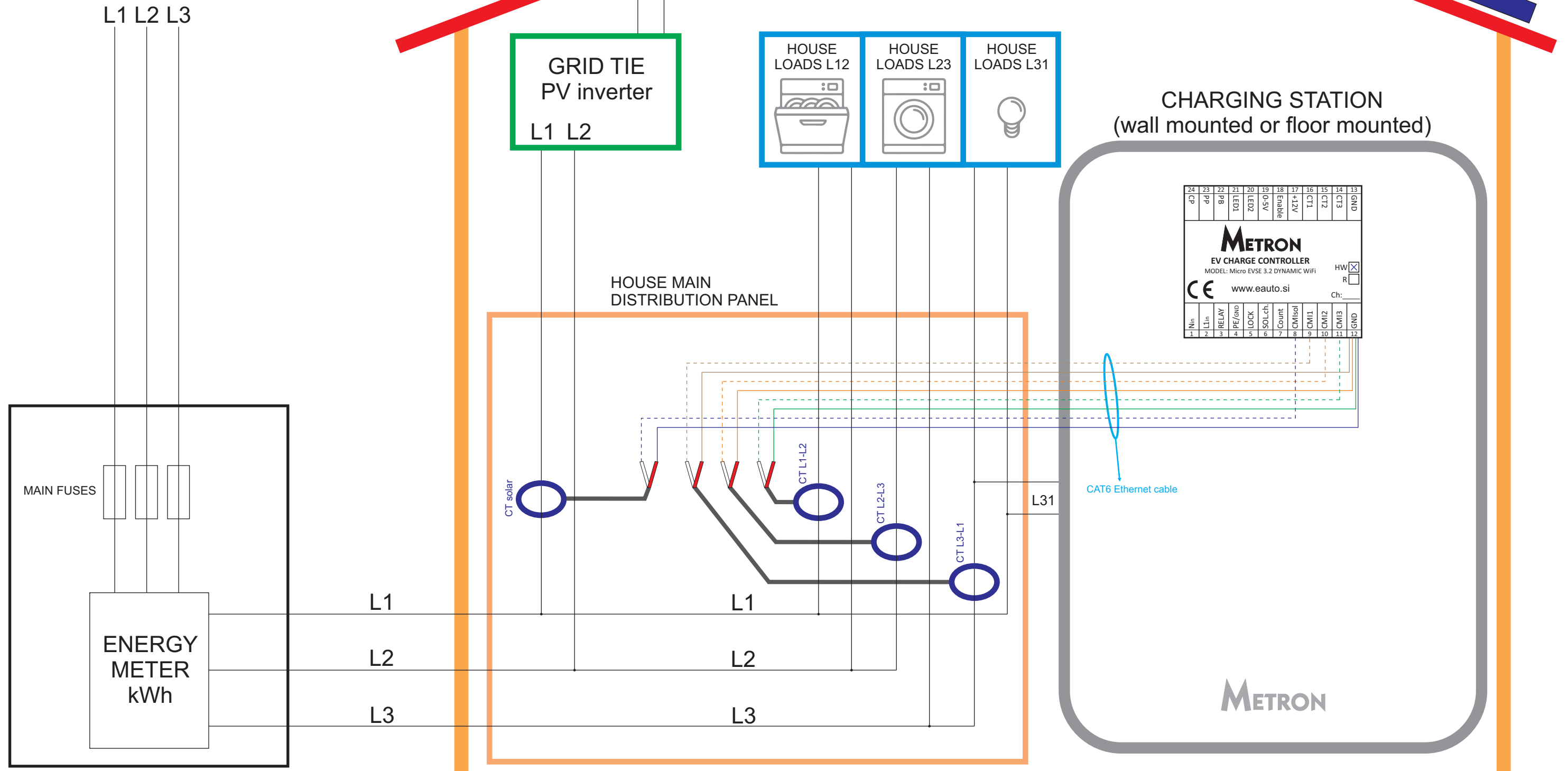

|   |       |       |         |      |        |       |        |      |      |      |      |
|---|-------|-------|---------|------|--------|-------|--------|------|------|------|------|
| 24  | 23    | 22    | 21      | 20   | 19     | 18    | 17     | 16   | 15   | 14   | 13   |
| CP  | PE    | LED1  | LED2    | 6-5V | Enable | +12V  | CT1    | CT2  | CT3  | CT3  | GNDS |
| <b>METRON</b><br>EV CHARGE CONTROLLER<br>MODEL: Micro EVSE 3.2 DYNAMIC WIFI<br>www.eauto.si<br>CE |       |       |         |      |        |       |        |      |      |      |      |
| 1   | 2     | 3     | 4       | 5    | 6      | 7     | 8      | 9    | 10   | 11   | 12   |
| N/in  | L1/in | RELAY | PE/zero | LOCK | SOL.ch | Count | CM1sol | CM11 | CM12 | CM13 | GNDS |

# INSTALLATION OF 3FD-3/3.1/3.2 DYNAMIC EV CHARGING UNIT; Micro EVSE 3/3.1/3.2 DYNAMIC WiFi based WALL/FLOOR-MOUNTED stations and Micro EVSE 4 based PORTABLE stations for **3-phase** DYNAMIC MAIN FUSE PROTECTION CHARGING of **ONE or MORE** electric vehicles on **3P+N grid** WIRELESS OPTION - UNIDIRECTIONAL

3f GRID 3P+N 230/400V/50Hz

L1 L2 L3 N

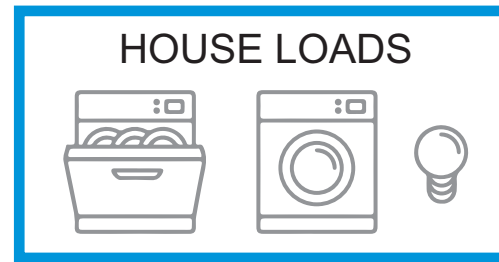
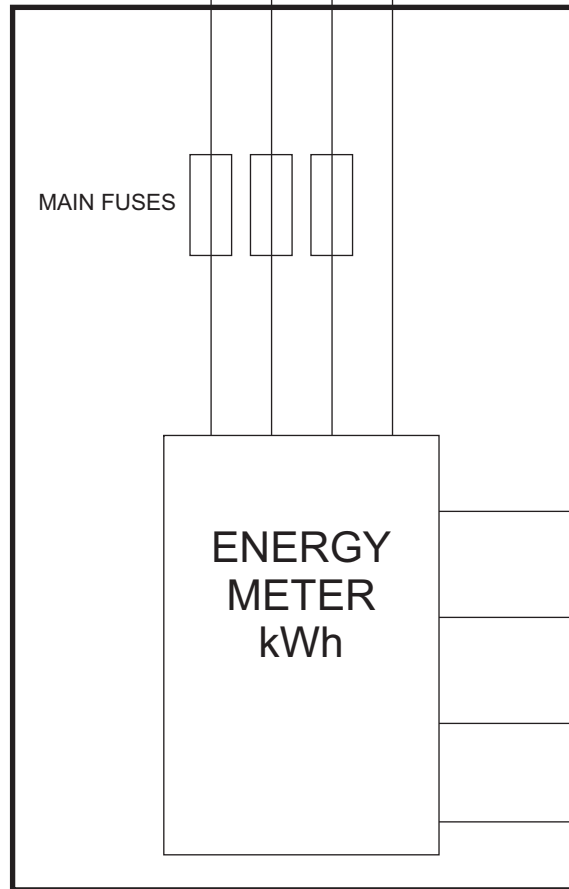

HOUSE MAIN DISTRIBUTION PANEL

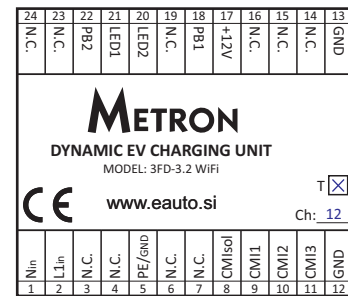

CT solar

L1

L2

L3

N

CTL1

CTL2

CTL3

L1

L2

L3

N

CHARGING STATION 2  
(wall mounted or floor mounted)

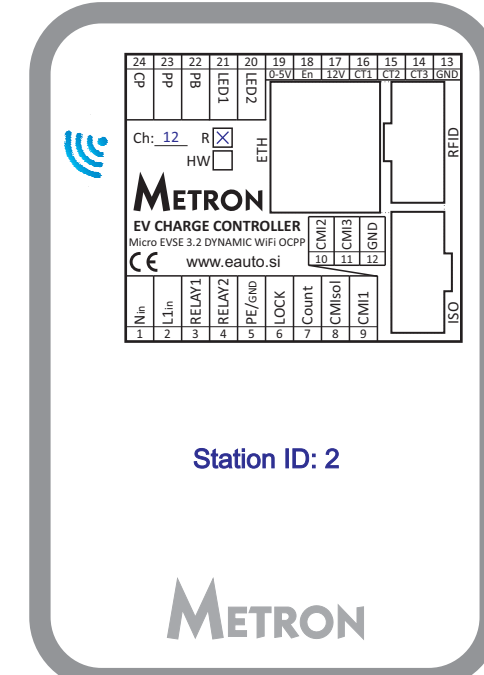

CHARGING STATION 4  
Station ID: 4



CHARGING STATION 1  
(wall mounted or floor mounted)

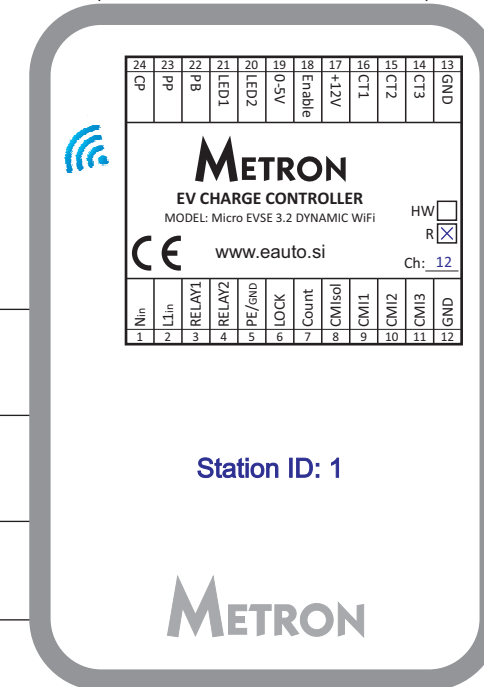

CHARGING STATION 3  
Station ID: 3



# INSTALLATION OF 3FD-3.2 DYNAMIC EV CHARGING UNIT; Micro EVSE 3/3.1/3.2 DYNAMIC WiFi based WALL/FLOOR-MOUNTED stations and Micro EVSE 4 based PORTABLE stations for **3-phase** DYNAMIC MAIN FUSE PROTECTION CHARGING of **ONE or MORE** electric vehicles on **3P+N grid** WIRELESS OPTION - BIDIRECTIONAL

3f GRID 3P+N 230/400V/50Hz

L1 L2 L3 N

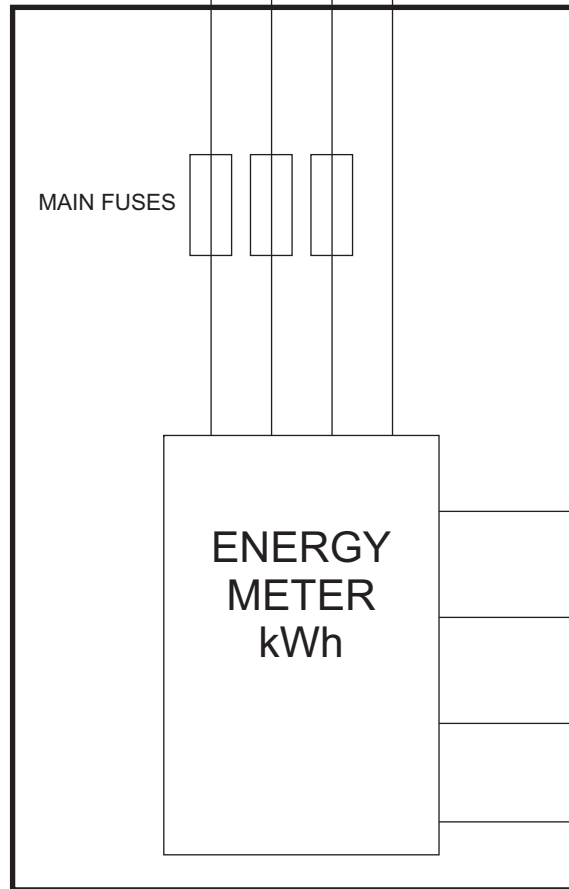

L1

L2

L3

N

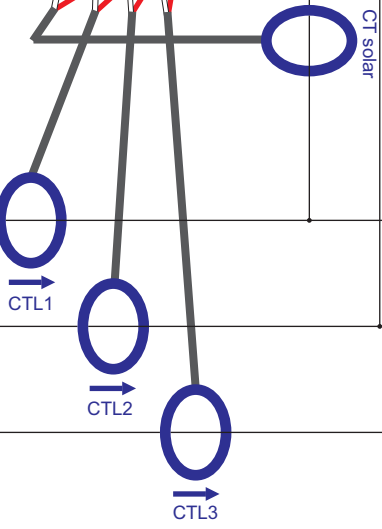
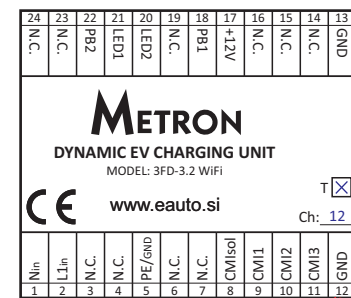
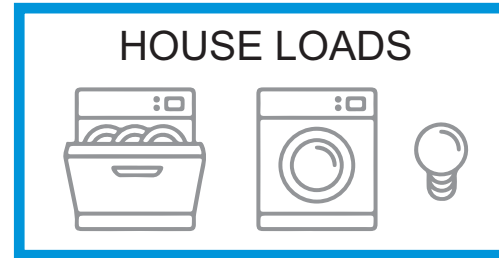

HOUSE MAIN DISTRIBUTION PANEL

CHARGING STATION 2  
(wall mounted or floor mounted)

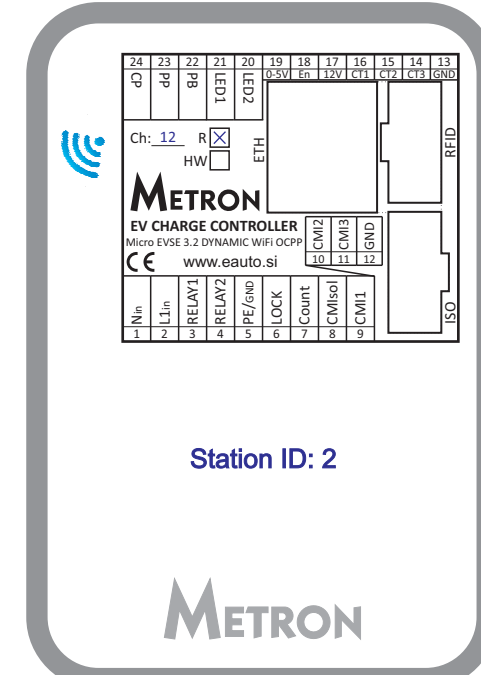

Station ID: 2

CHARGING STATION 4  
Station ID: 4



CHARGING STATION 1  
(wall mounted or floor mounted)

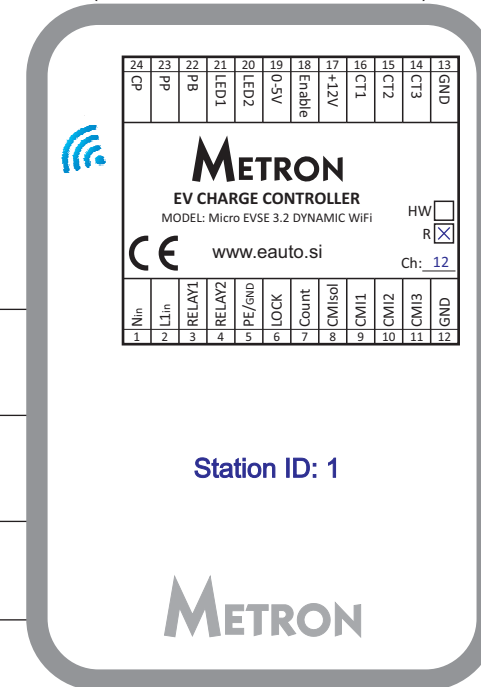

Station ID: 1

CHARGING STATION 3  
Station ID: 3



**INSTALLATION OF 3FD-3/3.1/3.2 DYNAMIC EV CHARGING UNIT; Micro EVSE 3/3.1/3.2 DYNAMIC WiFi based WALL/FLOOR-MOUNTED stations and Micro EVSE 4 based PORTABLE stations for 1-phase DYNAMIC MAIN FUSE PROTECTION CHARGING of ONE or MORE electric vehicles on 1P+N grid WIRELESS OPTION - UNIDIRECTIONAL**

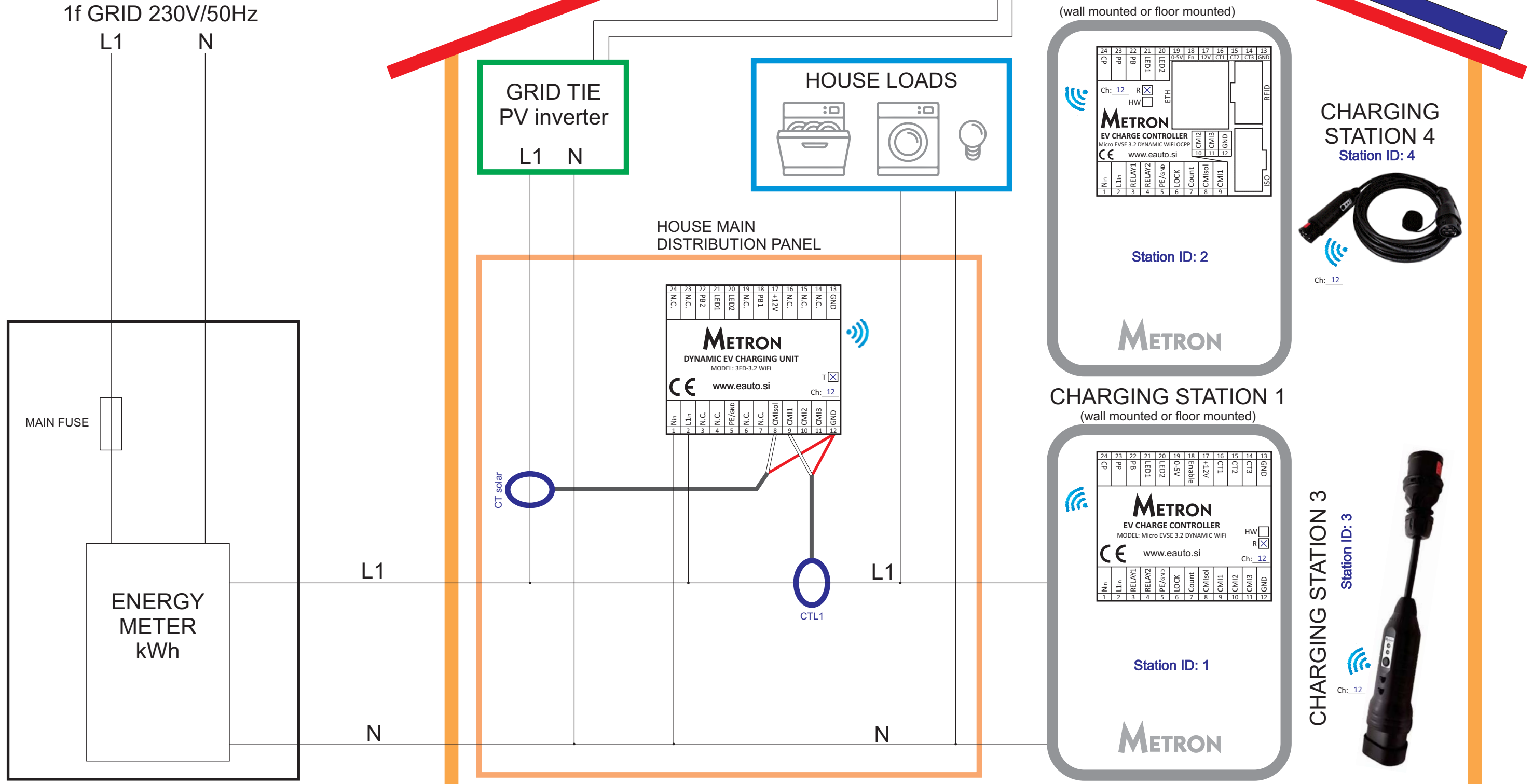



**INSTALLATION OF 3FD-3/3.1/3.2 DYNAMIC EV CHARGING UNIT; Micro EVSE 3/3.1/3.2 DYNAMIC WiFi based WALL/FLOOR-MOUNTED stations and Micro EVSE 4 based PORTABLE stations for 1-phase DYNAMIC MAIN FUSE PROTECTION CHARGING of ONE or MORE electric vehicles on 3P 230V grid (Belgium) WIRELESS OPTION**

3f GRID 3x230V/50Hz (Belgium)

